



**TACTICAL APPAREL FOR THE PROFESSIONAL  
MEN AND WOMEN**

*We have you in our sights*



**91.100 TACTICAL™**

**TACGEAR™**

**91.100 TACTICAL™** is pleased to introduce our TacGear™ product line. We think you'll agree that we have great products available for off-duty to extreme-duty law enforcement as well as other public safety personnel. All TacGear™ products are loaded with special features that enhance their durability and versatility while maintaining style & function. You can see this more completely described in the following pages.

**91.100 TACTICAL™** has adopted a new icon to stand beside our American Eagle. This great animal who was once king of the western plains, embodies the spirit we want to bring you with our TacGear™ line of products. Thousands of these majestic creatures roamed the western United States in herds as vast as the untouched space they occupied. That was until they were hunted to the brink of extinction, but now the American buffalo is coming back against staggering odds. This demonstration of endurance and the indomitable fortitude of this Great Animal should be the standard bearer everyone should hope to achieve in their own life and in this case our fine products. Please welcome the American buffalo as our chosen symbol of enduring strength to represent the new TacGear™ product line.

**TACGEAR™** is a product of

**91.100 TACTICAL™**

P O Box 58 Payson, Utah 84651

TEL 801.465.4313 <> Fax.801.465.4188 <> sales@91100tactical.com

[www.91100tactical.com](http://www.91100tactical.com)



# 91.100 TACTICAL™ TACPANTS™

## OFF DUTY SHORT

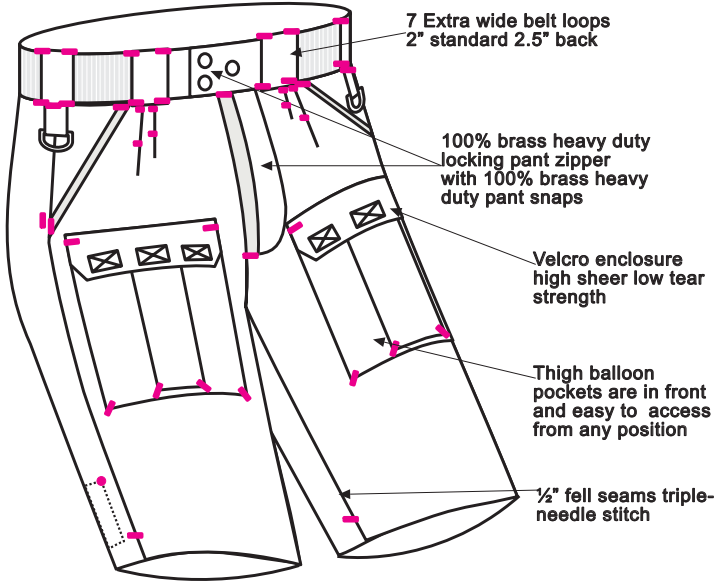

1. Ergonomically designed for absolute comfort with maximum degree of mobility and minimal restriction or resistance
2. Two secret hem pockets for ID/credentials or hand cuff keys inside pant leg
3. Conceal carried holster in each thigh pocket
4. Optional conceal carried holster "LAH"
5. Thigh Balloon pockets are in front and easy to access from any position
6. 7¼ ounce 65/35 Poly Cotton Twill sanforized to reduce shrinkage
7. Cordura trim on fly and slant front pockets for protection from high ware area
8. Reinforced knees

9. Extra wide belt loops
10. 4 "D" Rings attached to waist band
11. Durable pockets made of same poly cotton twill
12. 100% brass heavy duty locking pant zipper with 100% brass heavy duty pant snaps
13. Aplix model 800 high shear strength, low tear strength hook and loop velcro
14. Stitched with A&E T-80 Perma Core™ thread with mil spec tensile strength of 14lbs
15. Bar tacks as many as 168 depending on style
16. ½" fell seams triple-needle stitch
17. Lifetime manufacturer's guarantee

- Position of Bar Tacks
- Position of Spot Tacks

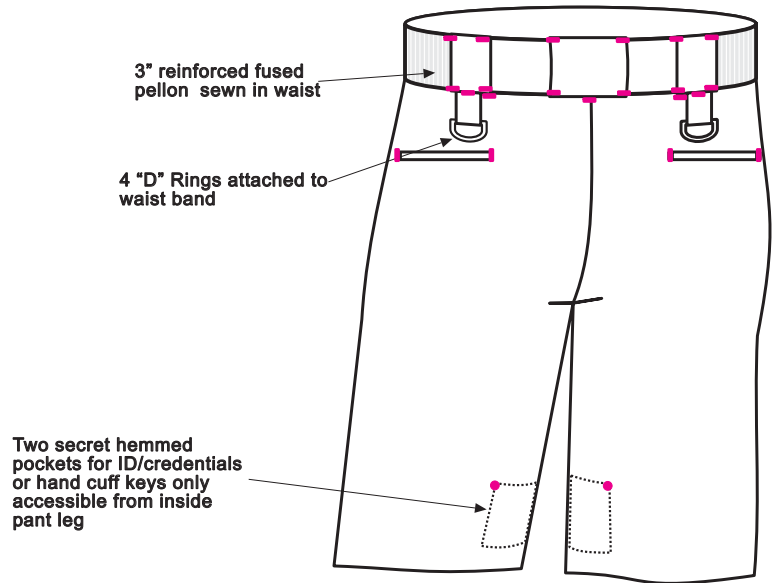



# 91.100 TACTICAL™ TACPANTS™

## OFF DUTY PANT

1. Ergonomically designed for absolute comfort with maximum degree of mobility and minimal restriction or resistance
2. Two secret hem pockets for ID/credentials or hand cuff keys inside pant leg
3. Conceal carried holster in each thigh pocket
4. Optional conceal carried holster "LAH"
5. Thigh Balloon pockets are in front and easy to access from any position
6. 7¼ ounce 65/35 Poly Cotton Twill sanforized to reduce shrinkage
7. Cordura trim on fly and slant front pockets for protection from high ware area
8. Reinforced knees
9. Knee pad pockets (optional knee pads)

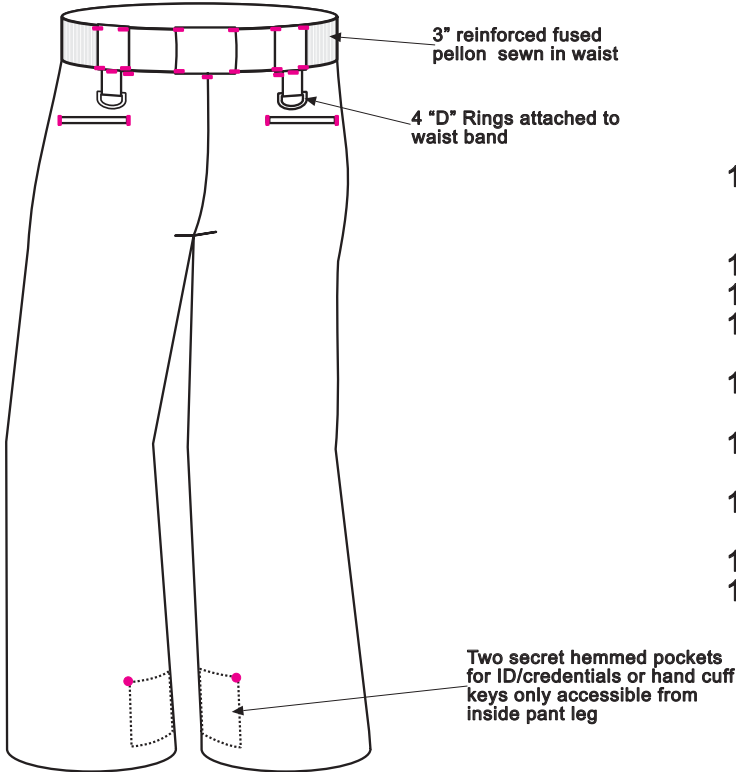
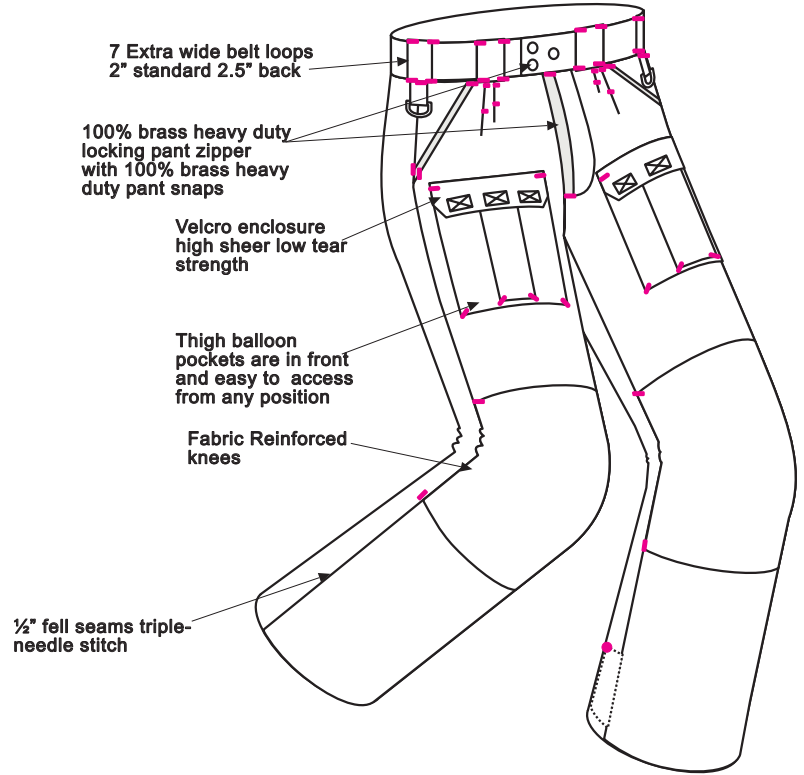

10. Stiffened and Reinforced 3" waist band with fused and sewn in pellon expandable by 8" incorporating 3" HD elastic
11. Extra wide belt loops
12. Durable pockets made of same poly cotton twill
13. 100% brass heavy duty locking pant zipper with 100% brass heavy duty pant snaps
14. Aplix model 800 high shear strength, low tear strength hook and loop velcro
15. Stitched with A&E T-80 Perma Core™ thread with mil spec tensile strength of 14lbs
16. Bar tacks as many as 168 depending on style
17. ½" fell seams triple-needle stitch
18. Lifetime manufacturer's guarantee

■ Position of Bar Tacks  
● Position of Spot Tacks





# 91.100 TACTICAL™ TACPANTS™

## DRESS GEAR PANTS

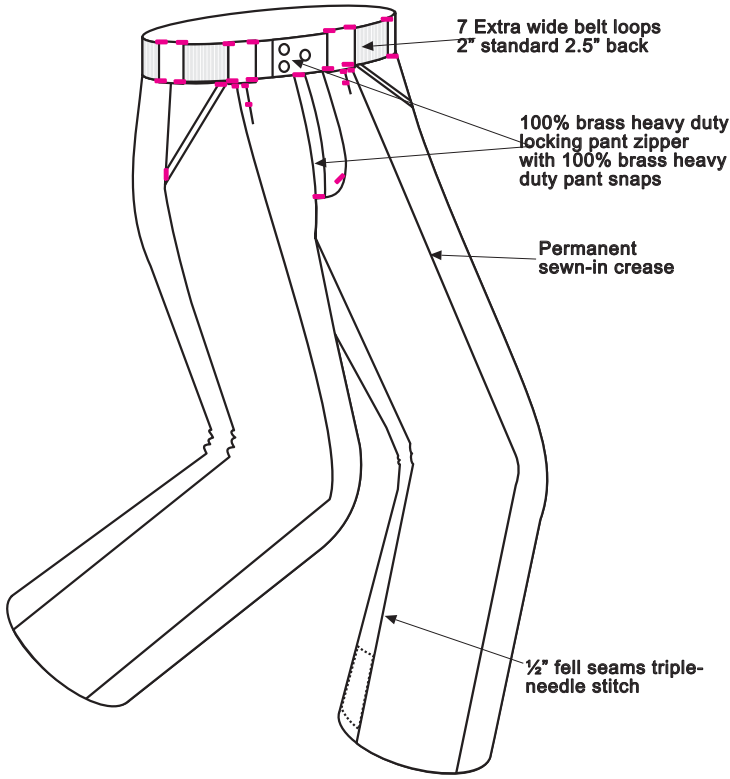

1. Ergonomically designed for absolute comfort with maximum degree of mobility and minimal restriction or resistance
2. Two secret hem pockets for ID, credentials or hand cuff keys
3. Optional Conceal carried holster "LAH"
4. 5¼ ounce 65/35 Poly Cotton Tudor sanforized to reduce shrinkage
5. Fabric trim on fly and slant front pockets for protection from high ware area
6. Slant pockets
7. Stiffened and Reinforced 3" waist band with fused and sewn in pellow expandable by 8" incorporating 3" HD elastic

8. 7 extra wide belt loops 2" standard 2.5" back
9. Durable pockets made of same poly cotton tudor
10. 100% brass heavy duty locking pant zipper with 100% brass heavy duty pant snaps
11. Stitched with A&E T-80 Perma Core™ thread with mil spec tensile strength of 14lbs
12. Bar tacks as many as 168 depending on style
13. ½" fell seams triple-needle stitch
14. Front sewn in crease
15. Lifetime manufacturer's guarantee

- Position of Bar Tacks
- Position of Spot Tacks

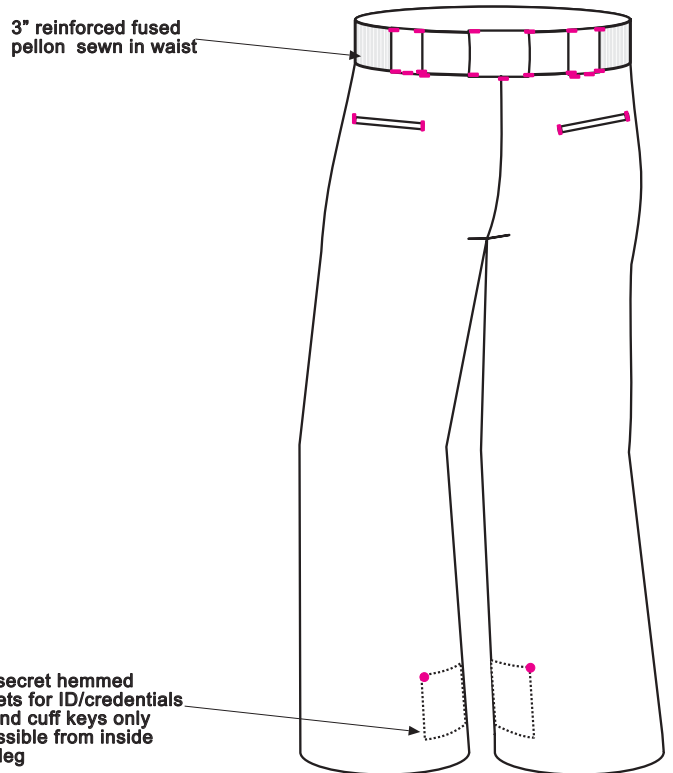

- |     |       |     |         |     |       |     |       |     |        |     |       |     |       |
|-----|-------|-----|---------|-----|-------|-----|-------|-----|--------|-----|-------|-----|-------|
| 001 | Black | 289 | DK Blue | 343 | Olive | 451 | Khaki | 428 | Silver | 422 | Stone | 476 | Brown |
|-----|-------|-----|---------|-----|-------|-----|-------|-----|--------|-----|-------|-----|-------|



# 91.100 TACTICAL™ TACPANTS™

## COVERT DUTY PANT

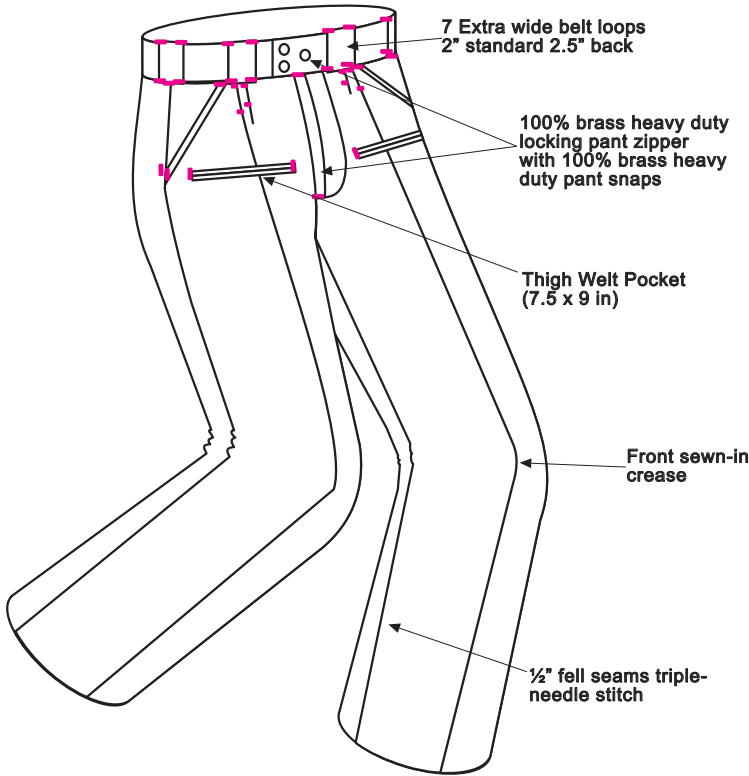

1. Ergonomically designed for absolute comfort with maximum degree of mobility and minimal restriction or resistance
2. Two secret hem pockets for ID, credentials or hand cuff keys
3. Conceal carried holster "LAH"
4. 5¼ ounce 65/35 Poly Cotton Tudor sanforized to reduce shrinkage
5. Fabric trim on fly and slant front pockets for protection from high ware area
6. Stiffened and Reinforced 3" waist band with fused and sewn in pellow expandable by 8" incorporating 3" HD elastic
7. 7 extra wide belt loops 2" standard 2.5" back

8. 4 "D" Rings attached to waist band
9. Durable pockets made of same poly cotton tudor
10. 100% brass heavy duty locking pant zipper with 100% brass heavy duty pant snaps
11. Stitched with A&E T-80 Perma Core™ thread with mil spec tensile strength of 14lbs
12. Bar tacks as many as 168 depending on style
13. ½" fell seams triple-needle stitch
14. Front sewn in crease
15. Lifetime manufacturer's guarantee

- Position of Bar Tacks
- Position of Spot Tacks

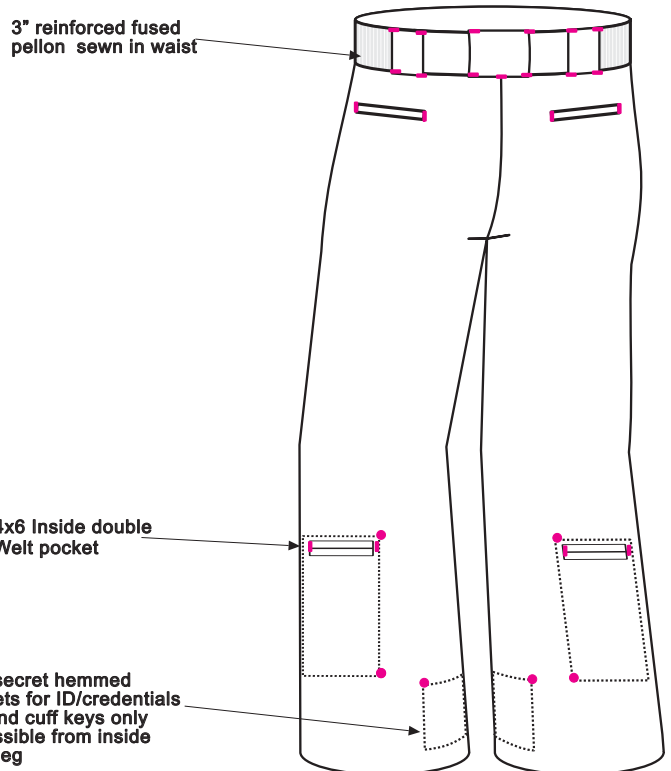

001 Black

289 DK Blue

343 Olive

451 Khaki

428 Silver

422 Stone

476 Brown



# 91.100 TACTICAL™ TACPANTS™

## STANDARD DUTY SHORT

1. Ergonomically designed for absolute comfort with maximum degree of mobility and minimal restriction or resistance
2. 16 pockets which includes two secret hem pockets for ID, credentials or hand cuff keys
3. Balloon pockets for extra storage capacity
4. Thigh Balloon pockets are in front and easy to access from any position
5. 2 standard concealed holsters with hook and loop strap to secure weapon
6. Optional 3<sup>rd</sup> conceal carried holster, "LAH"
7. 7¼ ounce 65/35 Poly Cotton Twill sanforized to reduce shrinkage
8. Cordura reinforced seat and action pockets
9. Cordura trim on fly and slant front pockets for protection from high ware area

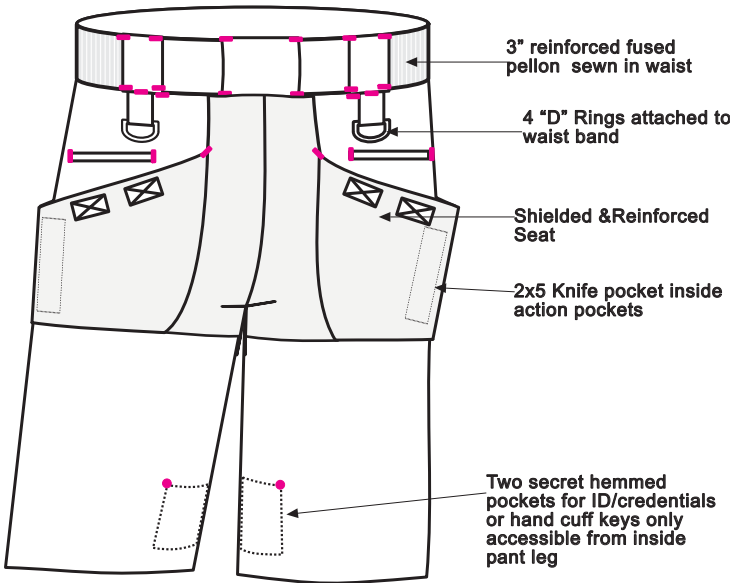
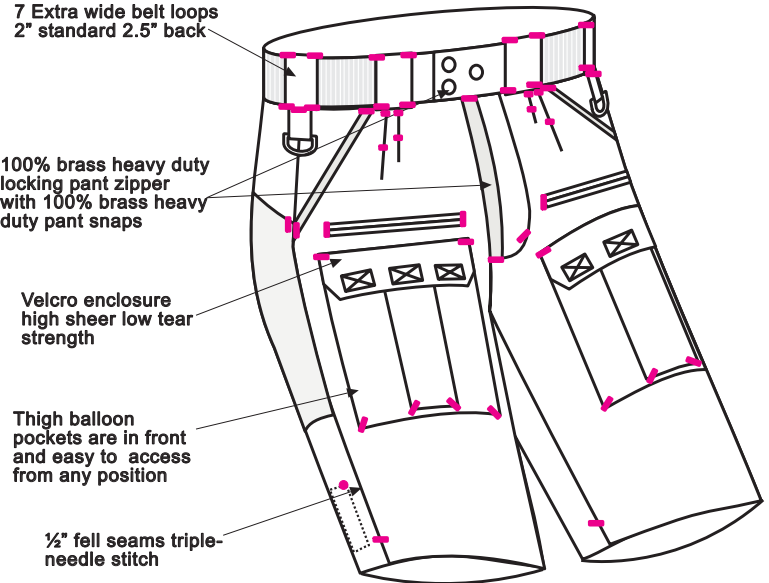

10. Stiffened and Reinforced 3" waist band with fused and sewn in pellow expandable by 8" incorporating 3" HD elastic
11. Extra wide belt loops
12. 4 "D" Rings attached to waist band
13. Durable pockets made of same poly cotton twill
14. 100% brass heavy duty locking pant zipper with 100% brass heavy duty pant snaps
15. Aplix model 800 high shear strength, low tear strength hook and loop on cargo pocket -flaps
16. Stitched with A&E T-80 Perma Core™ thread with mil spec tensile strength of 14lbs
17. Bar tacks as many as 168 depending on style
18. ½" fell seams triple-needle stitch
19. Lifetime manufacturer's guarantee

■ Position of Bar Tacks  
● Position of Spot Tacks





# 91.100 TACTICAL™ TACPANTS™

## STANDARD DUTY PANT

1. Ergonomically designed for absolute comfort with maximum degree of mobility and minimal restriction or resistance
2. 18 pockets which includes two secret hem pockets for ID, credentials or hand cuff keys
3. 703 Cubic Inches of storage capacity
4. Thigh Balloon pockets are in front and easy to access from any position
5. 2 standard concealed holsters with hook and loop strap to secure weapon
6. Optional 3<sup>rd</sup> conceal carried holster, "LAH"
7. 7¼ ounce 65/35 Poly Cotton Twill sanforized to reduce shrinkage
8. Cordura trim on fly and front pockets for protection from fraying
9. Cordura reinforced knees, seat and action pockets
10. Knee pad pockets (optional knee pads)

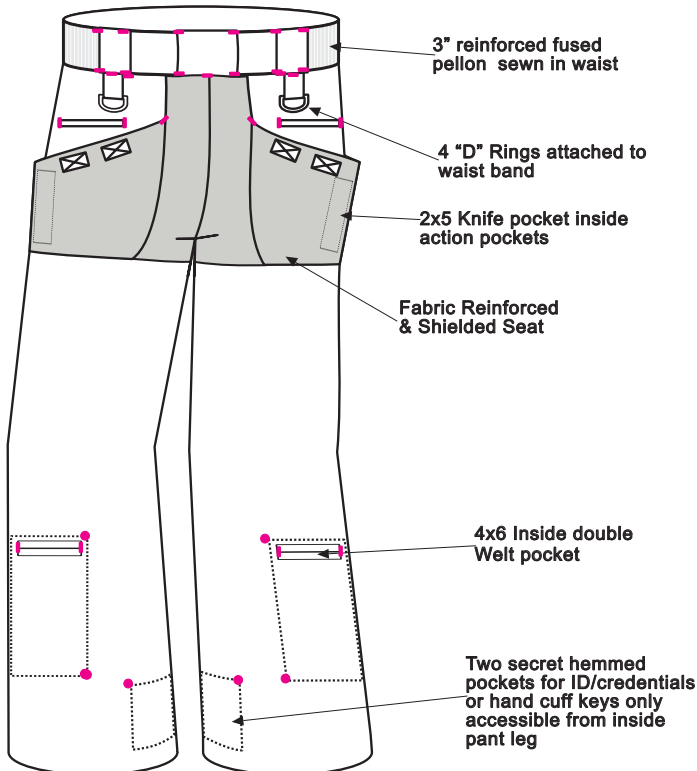

11. Stiffened and Reinforced 3" waist band with fused and sewn in pellow expandable by 8" incorporating 3" HD elastic
12. Extra wide belt loops
13. 4 "D" Rings attached to waist band
14. Durable pockets made of same poly cotton twill
15. 100% brass heavy duty locking pant zipper with 100% brass heavy duty pant snaps
16. Aplix model 800 high shear strength, low tear strength hook and loop velcro
17. Stitched with A&E T-80 Perma Core™ thread with mil spec tensile strength of 14lbs
18. 168 Bar tacks with 29 stitches per straight tack and 58 stitches per box "X" tacked
19. ½" fell seams triple-needle stitch
20. Lifetime manufacturer's guarantee

■ Position of Bar Tacks  
● Position of Spot Tacks

001 Black

289 DK Blue

343 Olive

451 Khaki

428 Silver

422 Stone

476 Brown



# 91.100 TACTICAL™ TACPANTS™

## HEAVY DUTY PANT

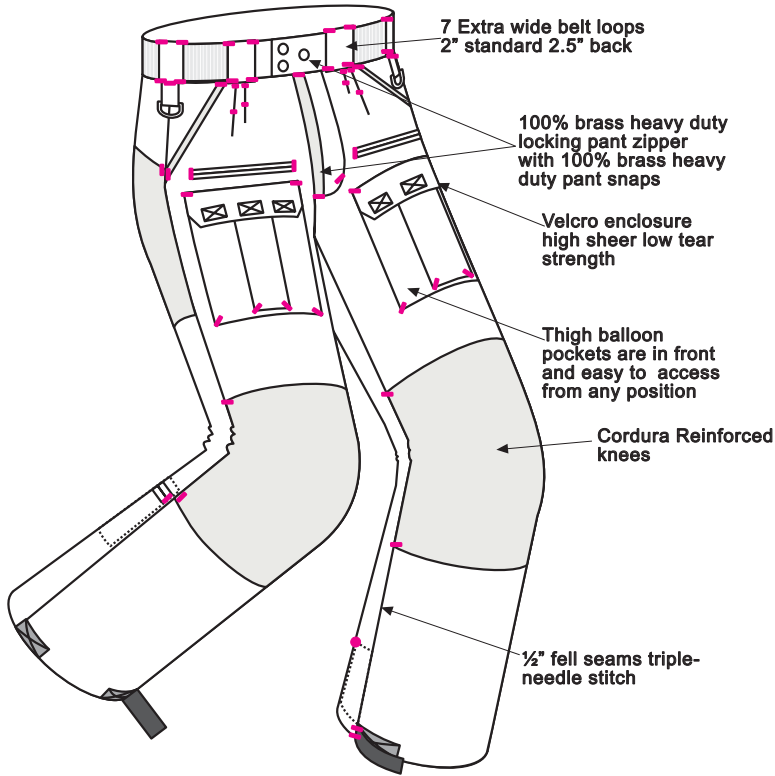

1. Ergonomically designed for absolute comfort with maximum degree of mobility and minimal restriction or resistance
2. 18 pockets which includes two secret hem pockets for ID, credentials or hand cuff keys
3. 703 Cubic Inches of storage capacity
4. Thigh Balloon pockets are in front and easy to access from any position
5. 2 standard concealed holsters with hook and loop strap to secure weapon
6. Optional 3<sup>rd</sup> conceal carried holster, "LAH"
7. 7¼ ounce 65/35 Poly Cotton Twill sanforized to reduce shrinkage
8. Cordura trim on fly and front pockets for protection from fraying
9. Cordura reinforced knees, seat and action pockets
10. Knee pad pockets w/ knee pads

11. Optional sewn in butt pads
12. Stiffened and Reinforced 3" waist band with fused and sewn in pellow expandable by 8" incorporating 3" HD elastic
13. 7 Extra wide belt loops 2" standard 2.5" back
14. 4 "D" Rings attached to waist band
15. Durable pockets made of same poly cotton twill
16. 100% brass heavy duty locking pant zipper with 100% brass heavy duty pant snaps
17. Aplix model 800 high shear strength, low tear strength hook and loop velcro
18. Stitched with A&E T-80 Perma Core™ thread with mil spec tensile strength of 14lbs
19. 168 Bar tacks with 29 stitches per straight tack and 58 stitches per box "X" tacked
20. ½" fell seams triple-needle stitch
21. Lifetime manufacturer's guarantee

- Position of Bar Tacks
- Position of Spot Tacks

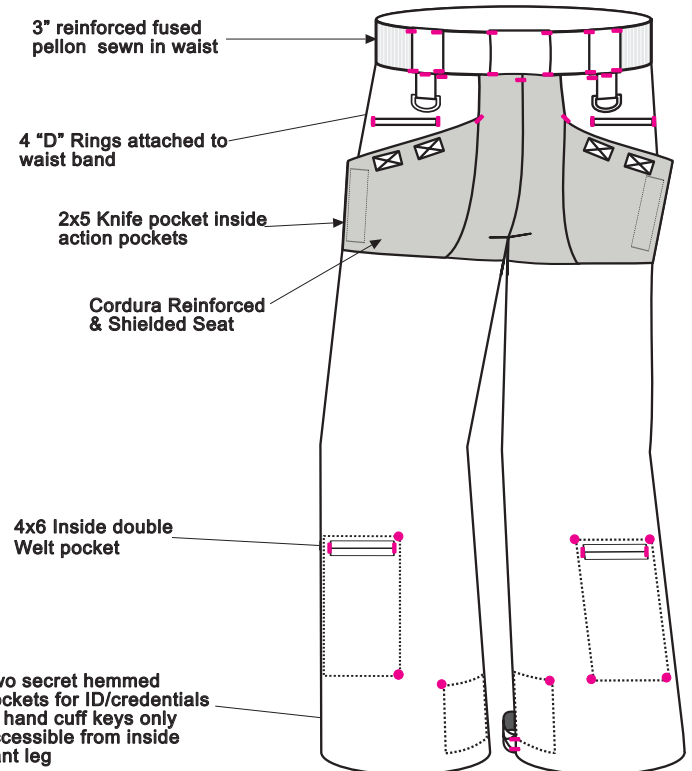

001 Black

289 DK Blue

343 Olive

451 Khaki

428 Silver

422 Stone

476 Brown



# 91.100 TACTICAL™ TACPANTS™

## EXTREME DUTY PANT

1. Ergonomically designed for absolute comfort with maximum degree of mobility and minimal restriction or resistance
2. 18 pockets which includes two secret hem pockets for ID/credentials or hand cuff keys
3. 703 Cubic Inches of storage capacity
4. Thigh Balloon pockets are in front and easy to access from any position
5. 2 standard concealed holsters with hook and loop strap to secure weapon
6. Optional 3<sup>rd</sup> conceal carried holster, "LAH"
7. 7¼ ounce 65/35 Poly Cotton Twill sanforized to reduce shrinkage
8. Cordura trim on fly and front slant pockets for protection from fraying
9. Kevlar reinforced knees, seat and action pockets
10. Knee pad pockets w/ knee pads

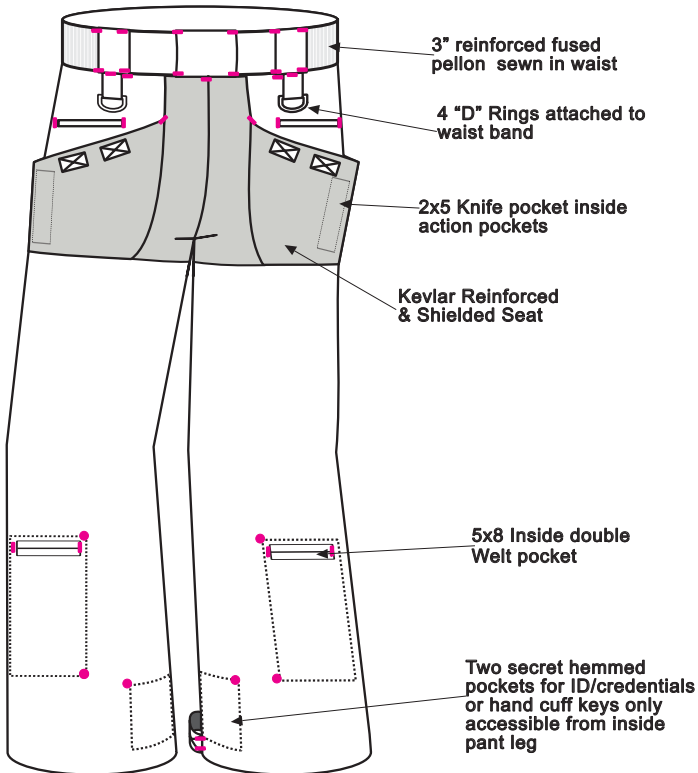
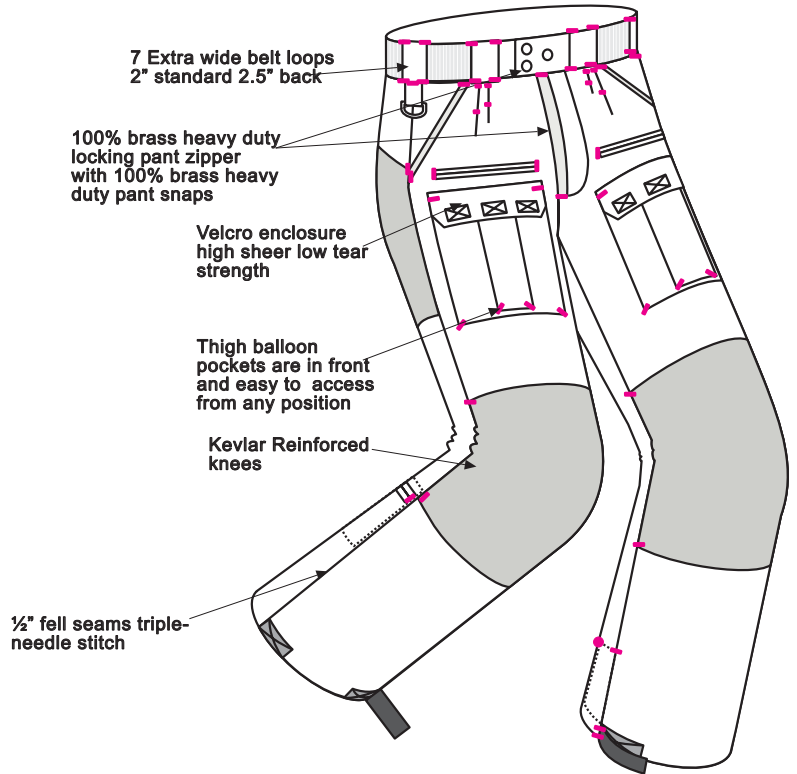

11. Optional sewn in butt pads
12. Stiffened and Reinforced 3" waist band with fused and sewn in pellow expandable by 8" incorporating 3" HD elastic
13. 7 Extra wide belt loops 2" standard 2.5" back
14. 4 "D" Rings attached to waist band
15. Durable pockets made of same poly cotton twill
16. 100% brass heavy duty locking pant zipper with 100% brass heavy duty pant snaps
17. Aplix model 800 high shear strength, low tear strength hook and loop velcro
18. Stitched with A&E T-80 Perma Core™ thread with mil spec tensile strength of 14lbs
19. 168 Bar tacks with 29 stitches per straight tack and 58 stitches per box "X" tacked
20. ½" fell seams triple-needle stitch
21. Lifetime manufacturer's guarantee

■ Position of Bar Tacks  
● Position of Spot Tacks











# 91.100 TACTICAL™ TACPANTS™

## SIZE, COLOR AND PRICING CHARTS

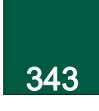
Note: All measurements are in inches.		TacPant Size Chart							TacPant™ Size Chart Rev (2m) 4/25/08
Description:	XSmall	Small	Medium	Large	X Large	2X Large	3X Large	4X Large	
Waist (Relaxed)	27	29	31	34	36	36	39	44	
Waist (Stretched)	36	38	40	42	45	46	49	54	
Waist (Nominal)	30	32	34	36	38	40	43	47	
Short Inseam	30	30	30	30	30	30	30	30	
Regular Inseam	32	32	32	32	32	32	32	32	
Tall Inseam	34	34	34	34	34	34	36	36	
Unhemmed Inseam	34	36	38	38	38	38	38	38	

TacPant Pricing Chart				
Style:	XS - XL	2XL	3XL	4XL
Bike pant Undergarment	\$49.95	\$54.95	\$59.95	\$59.95
Off Duty Short	\$104.95	\$134.95	\$139.95	\$144.95
Standard Duty Short	\$131.95	\$161.95	\$166.95	\$171.95
Covert Pant	\$181.95	\$211.95	\$216.95	\$221.95
Dress Pant	\$154.95	\$184.95	\$189.95	\$194.95
Off Duty Pant	\$174.95	\$204.95	\$209.95	\$214.95
Standard Duty Pant	\$204.95	\$234.95	\$239.95	\$244.95
Heavy Duty Pant	\$249.95	\$279.95	\$284.95	\$289.95
Extreme Duty Pant	\$289.95	\$329.95	\$334.95	\$339.95

-  001 Black
-  289 DK Blue
-  343 Olive
-  451 Khaki
-  428 Silver
-  422 Stone
-  476 Brown

