

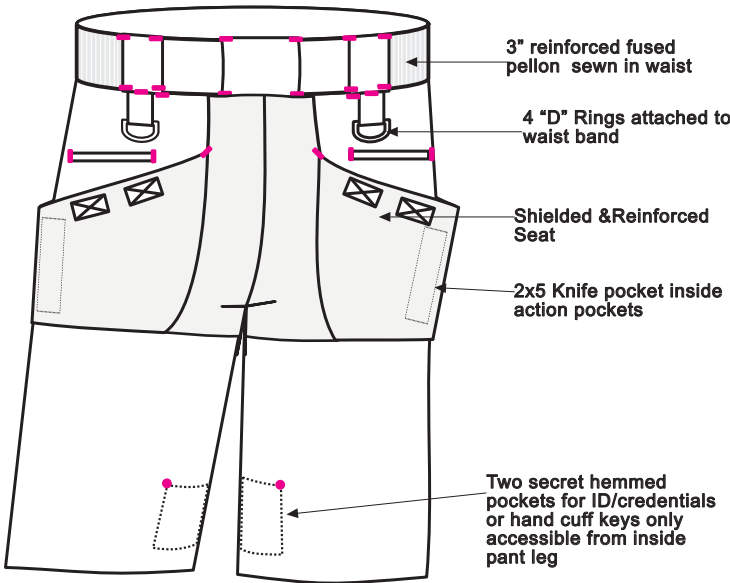

# 91.100 TACTICAL™ TACPANTS™

## STANDARD DUTY SHORT

1. Ergonomically designed for absolute comfort with maximum degree of mobility and minimal restriction or resistance
2. 16 pockets which includes two secret hem pockets for ID, credentials or hand cuff keys
3. Balloon pockets for extra storage capacity
4. Thigh Balloon pockets are in front and easy to access from any position
5. 2 standard concealed holsters with hook and loop strap to secure weapon
6. Optional 3<sup>rd</sup> conceal carried holster, "LAH"
7. 7¼ ounce 65/35 Poly Cotton Twill sanforized to reduce shrinkage
8. Cordura reinforced seat and action pockets
9. Cordura trim on fly and slant front pockets for protection from high ware area

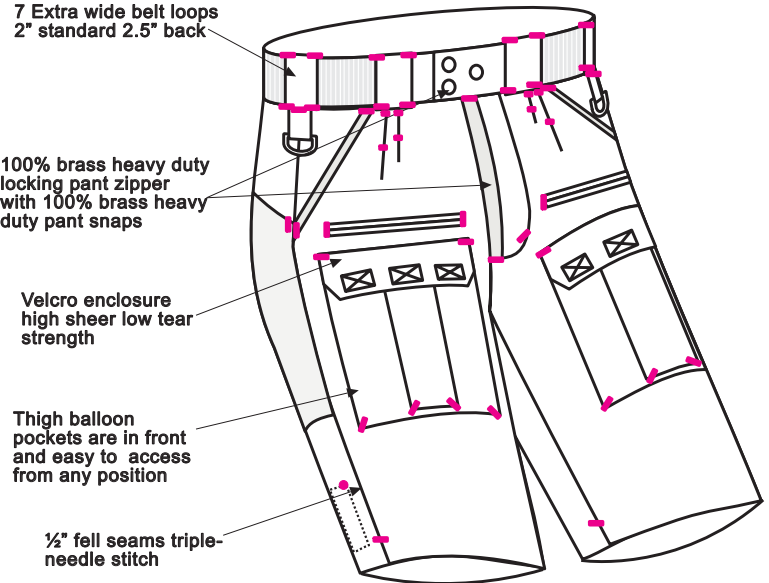

10. Stiffened and Reinforced 3" waist band with fused and sewn in pellow expandable by 8" incorporating 3" HD elastic
11. Extra wide belt loops
12. 4 "D" Rings attached to waist band
13. Durable pockets made of same poly cotton twill
14. 100% brass heavy duty locking pant zipper with 100% brass heavy duty pant snaps
15. Aplix model 800 high shear strength, low tear strength hook and loop on cargo pocket -flaps
16. Stitched with A&E T-80 Perma Core™ thread with mil spec tensile strength of 14lbs
17. Bar tacks as many as 168 depending on style
18. ½" fell seams triple-needle stitch
19. Lifetime manufacturer's guarantee

■ Position of Bar Tacks  
● Position of Spot Tacks

